



## **Quality Boiler Mag Gages, The Simple Water Column Solution**

The Quality Boiler Mag Gage Assembly complete with the Quality Boiler Water Gage Assembly is a simple and efficient replacement for the old style water column. These units, suitable up to 2000 lb Steam, can be used as a direct retrofit to an existing unit, or installed on new units to meet all of your requirements.

The Quality Boiler Mag Gage is available with point level switches to replace the conductivity probes in the old style water column, or we are able to supply a magnetostrictive liquid level transmitter which offers a 4-20ma 2 wire loop powered circuit for continuous indirect level measurement.

All units are also supplied with a flag indicting indirect system.

These units are also supplied with a Quality Boiler Water Gage Glass assembly, thereby giving the customer a complete system which conforms to ASME Boiler Code by supplying 1 Direct Reading, and 2 Remote Reading Gauges for units 900psig and above.

### **Information Required for Ordering:**

- 1) Maximum Design Pressure
- 2) Steam/Water connections required
- 3) Center to Center for Steam/Water connections
- 4) Location and Orientation of Connections
- 5) Location and Orientation of Point Level Switches
- 6) Location and Orientation of Flag Indicator
- 7) Boiler Gage Visibility range
- 8) Location and Orientation of Boiler Gage
- 9) Environmental Conditions

PROCESS CODE

REV.	BY	REVISION	DATE
0	BY	DESC.	DATE

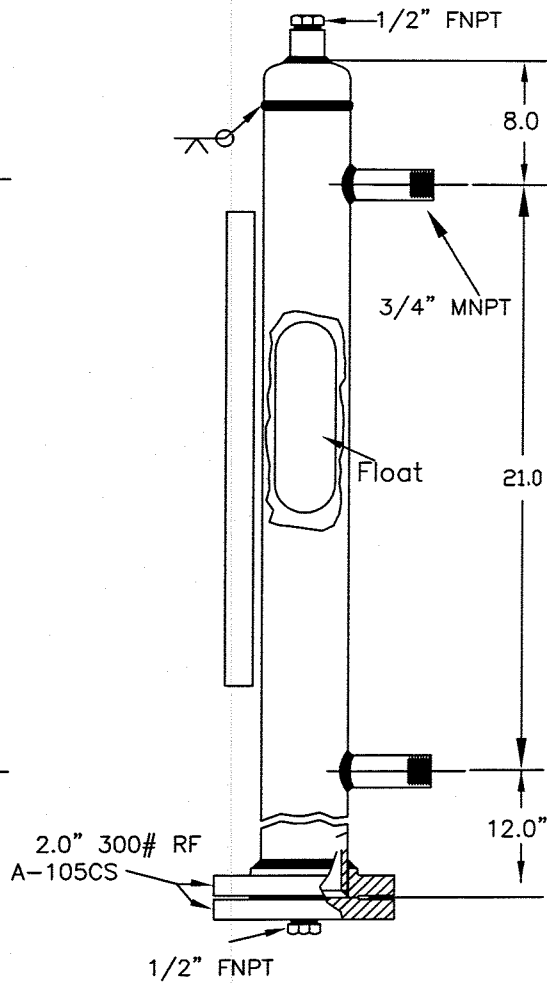
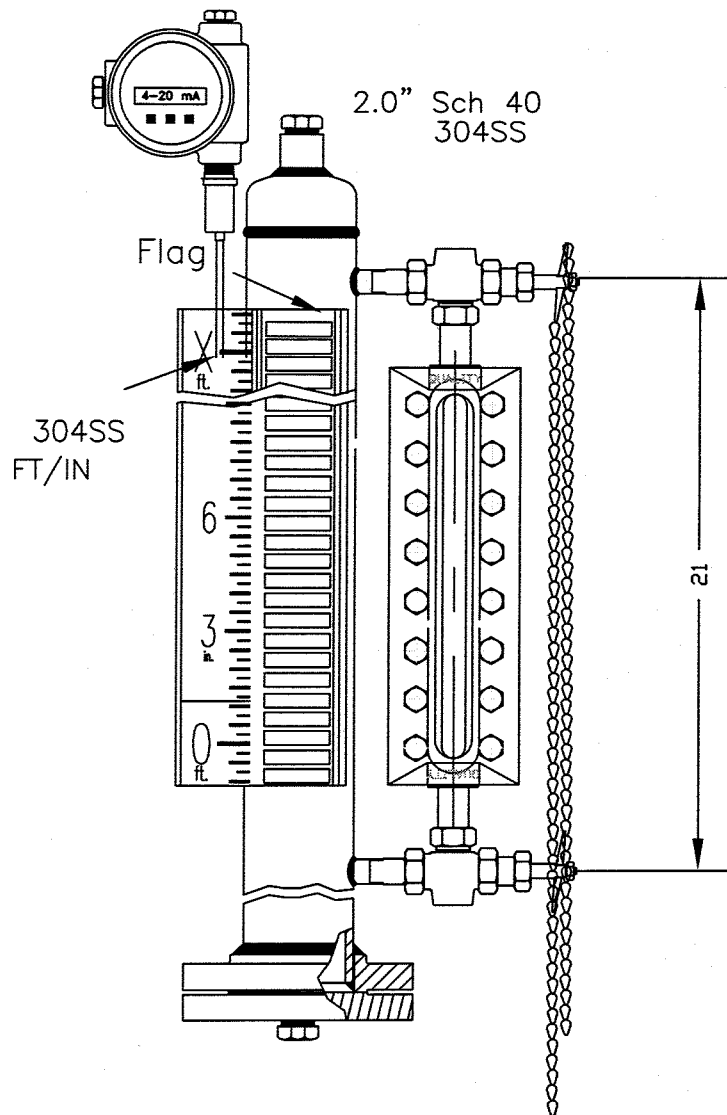

**CONFIDENTIAL**  
 ALL THE INFORMATION CONTAINED IN THIS DOCUMENT CONSTITUTES A CONFIDENTIAL DISCLOSURE BY QUALITY MACH&METAL'S INC. AND REMAINS IT'S EXCLUSIVE PROPERTY. ANY REPRODUCTION IN WHOLE OR IN PART IS PROHIBITED WITHOUT THE WRITTEN PERMISSION OF QUALITY MACHINING & METALWORKS Inc.

TOLERANCES: UNLESS OTHERWISE NOTED  
 .XX±.03 .XXX±.002  
 ANGLES±1° FRACTIONS±1/16

MATERIAL: MATERIAL

Q M&M QUALITY MACHINING & METALWORKS Inc.  
 1655 Enterprise Rd. Mississauga ON, L4W 4L4

QBM-300#ANSI

DRAWN BY: BC	DATE: DATE
APPROVED BY: SC	SCALE: SCALE
DRAWING NO. 98-100	REVISION R SHEET SHT